

**3406 Port Union Road  
Hamilton, OH 45015**

**Industrial Space For  
Lease  
14,000 SF**

**NORTH RIDGE**  
REALTY GROUP  
COMMERCIAL REAL ESTATE



**AVAILABLE:**

14,000 SF free-standing on 2.294 acres

**USES:**

Light industrial / Flex

**OFFERED AT:**

\$8.50 PSF NNN

\$1.50 PSF OpEx

**LOCATION:**

Located in City of Hamilton minutes to I-275, I-75 & SR1-29

**SUMMARY:**

- 1 drive-in & 1 dock
- 20'-23' clear
- 480-volt, 3 Phase, 400 amps
- Wet sprinkled



**North Ridge Realty Group**

7182 Liberty Centre Drive, Suite M  
West Chester, OH 45069

**Marshall Stretch**

VP Sales & Leasing  
513.504.8232 Mobile

**John Stretch**

Broker / Owner  
513.623.6505 Mobile

Disclaimer: The Realtor involved in selling the premises is relying on all information provided herein or supplied by owner or owner's sources in connection with the Real Estate. We cannot guarantee this information.

# OVERVIEW

3400 Port Union Rd.  
Hamilton, OH  
45015  
Industrial Space  
For Lease

**YEAR BUILT:**  
2015

**OCCUPANCY:**  
Immediate

**SPACE INFO:**

- Approximately 14,000 SF (13,665 SF warehouse & 335 SF office) + 415 SF mezzanine
- 415 SF mezzanine not included in square footage
- One electric drive-in door - 14'x14'
- One dock door w/ edge of dock leveler - 8'x9'
- 480-volt, 3 Phase, 400 amps
- 20'-23' clear
- LED lighting
- Wet sprinkled
- Gas fired heater in warehouse

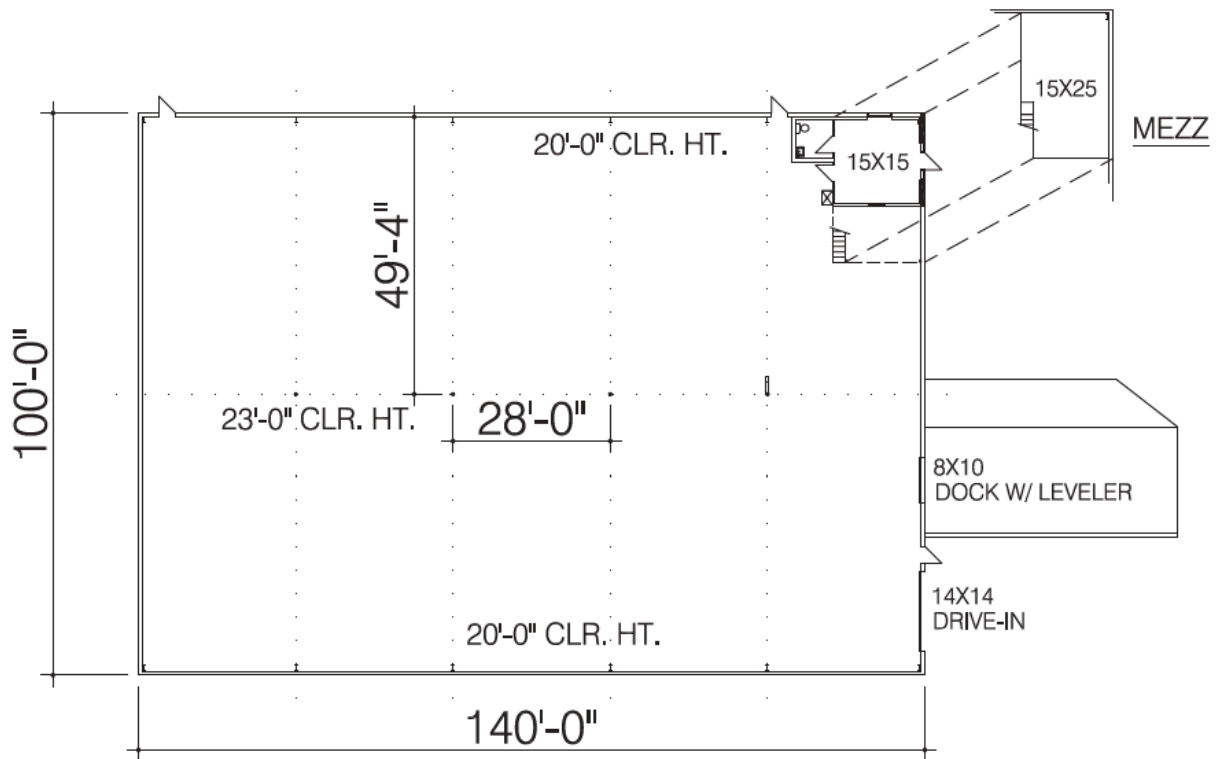

FLOOR PLAN 

10 25 50

OFFICE	335 SF
WHSE	13,665 SF
MEZZ	415 SF
TOTAL	14,415 SF

**North Ridge Realty Group**  
7182 Liberty Centre Drive, Suite M  
West Chester, OH 45069

**Marshall Stretch**  
VP Sales & Leasing  
513.504.8232 Mobile

**John Stretch**  
Broker / Owner  
513.623.6505 Mobile

Disclaimer: The Realtor involved in selling the premises is relying on all information provided herein or supplied by owner or owner's sources in connection with the Real Estate. We cannot guarantee this information.

# PROPERTY PHOTOS

3400 Port Union  
Rd.  
Hamilton, OH  
45015  
Industrial Space  
For Lease



**North Ridge Realty Group**  
7182 Liberty Centre Drive, Suite M  
West Chester, OH 45069

**Marshall Stretch**  
VP Sales & Leasing  
513.504.8232 Mobile

**John Stretch**  
Broker / Owner  
513.623.6505 Mobile

Disclaimer: The Realtor involved in selling the premises is relying on all information provided herein or supplied by owner or owner's sources in connection with the Real Estate. We cannot guarantee this information.

# STREET MAP

3400 Port Union  
Rd.  
Hamilton, OH  
45015  
Industrial Space  
For Lease

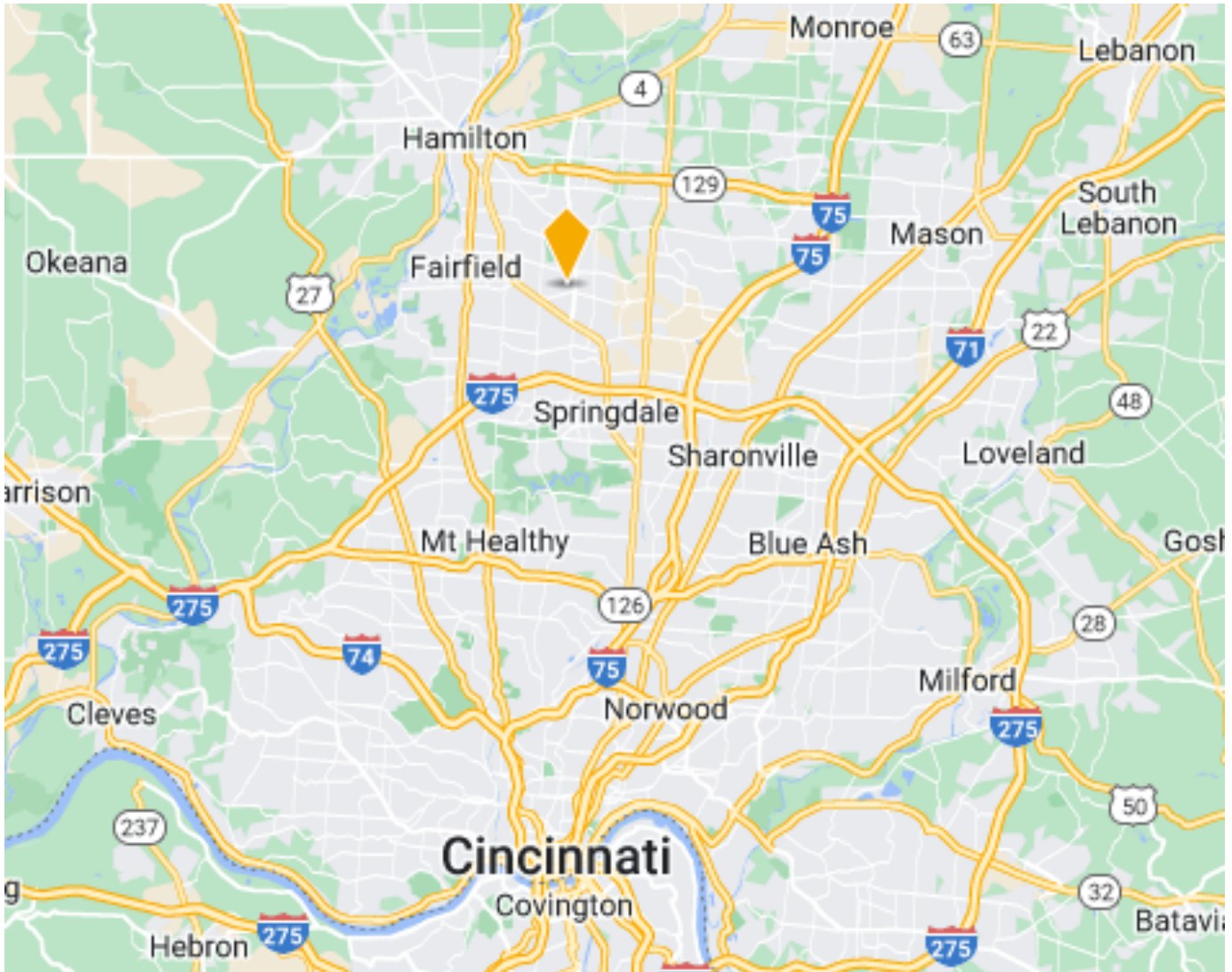

**North Ridge Realty Group**  
7182 Liberty Centre Drive, Suite M  
West Chester, OH 45069

**Marshall Stretch**  
VP Sales & Leasing  
513.504.8232 Mobile

**John Stretch**  
Broker / Owner  
513.623.6505 Mobile

Disclaimer: The Realtor involved in selling the premises is relying on all information provided herein or supplied by owner or owner's sources in connection with the Real Estate. We cannot guarantee this information.